



EI45



CLASSIC



U_d VALUE
(W/m² * K)

EI



MAXIMUM
LOAD



SEALS

MINI



FIRE RESISTANT
SEAL



PROTECTIVE
FEET

FLEX



HANDRAIL



YEARS
GUARANTEE

SOLID



The mark of
responsible forestry



COMPLIANCE WITH
THE STANDARD

LONG

GOLDWOOD

EI45

66 mm

The EI45 loft ladders are characterized by double sealing, including a single fire resistant sealing and hatch thickness 66mm. The EI45 loft ladders have the EI45 fire resistance class. The EI45 model is ideally suited for installation in rooms particularly exposed to fire outbreak. Their fire safety properties allows an effective isolation of the room, in which the fire occurred from the attic. The loft ladders have anti skidding feet, they adheres perfectly to the ground, prevent scratching of the floor and provide an aesthetic finish for the ladder after cutting. For increased safety and convenience of use, EI45 loft ladders are equipped in a stable and durable handrail. In the interest of user convenience, the handrail can be installed on the left or right side – depending on the customer preferences. The excellent quality of materials used for the production of loft ladders and attention to every detail of finish cause that the stairs will satisfy even the most demanding customers. Their maximum load during use is up to 160 kg.

Technical specification

Insulated hatch thickness	66 mm
Thickness of thermal insulation	60 mm
Hatch colour from both sides	White
Wooden ladder	3 sections
Height of wooden box	170 mm
Width of ladder	400 mm
Width of step	358 mm
Depth of step	80 mm
Landing space	145 cm
Opening distance/angle	168 cm
Maximum ceiling height	280 cm

Box dimensions [cm] AxB

120x60 130x60

120x70 130x70

Outer box dimensions, mounting opening 2 cm larger

Accessories



Masking batten



Mounting system



Hatch balustrade

Technical draw

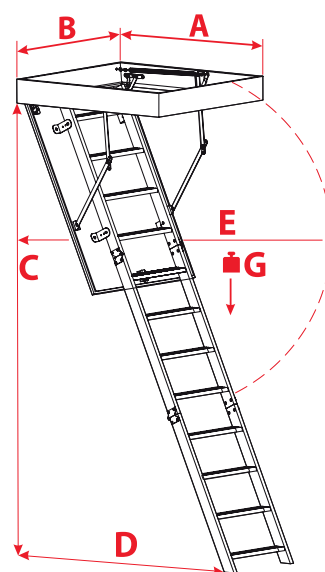

C	280 cm
D	145 cm
E	168 cm
G	160 kg